

# Optimization Water Conservation Through IoT Sensor Implementation At Smartneasy Nusantara

**Alfin Abdurrafi<sup>1</sup>, Donny Maulana<sup>2</sup>, Nanang Tedi Kurniadi<sup>3</sup>**

<sup>1,2,3</sup>*Informatics Engineering, Universitas Pelita Bangsa, Indonesia*

*E-mail : alfin.abdurrafi99@mhs.pelitabangsa.ac.id<sup>1</sup>, donny.maulana@pelitabangsa.ac.id<sup>2</sup>  
nanang@pelitabangsa.ac.id<sup>3</sup>*

*\*Corresponding author*

---

**Abstract** – The use of IoT sensors in technology is a fascinating research subject due to the possibility of real-time monitoring of water usage and temperature effects. Developing tools and systems that make observations of water usage through Max6675 sensors can optimize data collection and processing through remote monitoring. Utilizing the IoT technique, the ESP8266 WeMOS D1 R2 microcontroller and the Max6675 temperature sensor are utilized to regulate the water pump via a relay. This approach enhances water sustainability for plant assumptions based on the predetermined temperature. The device activates the water pump when the temperature surpasses the standard level at the observation site. The outcome indicated that this device operates accordingly with a 100% success rate. The device was determined to function effectively by activating the water pump based on temperature. Additionally, it can provide real-time monitoring data and process sensor data for analysis.

**Keywords** – IoT, Microcontroller, ESP8266 WeMOS, Max6675, Real Time.

## 1. INTRODUCTION

---

Electricity and water are essential resources for humans, with electricity being used to power electronic devices that facilitate human work. However, the usage of these resources is often unregulated, necessitating the implementation of water conservation techniques using IoT technology to optimize their usage. Mismanagement of water in an ungoverned industrial setting would lead to wasteful usage and hinder growth [1]. PT Smartneasy Nusantara Semesta is a company established in 2010. This PT is engaged in agriculture, one of which is melon plantations. In its implementation, this PT has not been able to fully optimize water conservation, which is the basis for conducting research by creating an innovation to facilitate the water conservation process using IoT sensors.

Using water, sometimes users are less able to control the use of water and lack the knowledge that users have to read water meters when monitoring, causing water bills that can increase at the end of the month such as in one of the houses in Pancor, East Lombok Regency. In this area, the monitoring process is still carried out in a conventional way, namely checking the water meter used. The lack of effectiveness of this water checking and control process causes the community to be less efficient in using distribution water considering the current technological developments that can help with these problems [1].

One form of advancement in the field of information technology is the Internet of Things (IoT) platform. One aspect that can apply this concept is the agricultural industry. Hydroponics

is a method of cultivating plants using water and nutrient solutions as a growing medium. The condition of water in hydroponics is very important to check regularly because it affects nutrient uptake and nutrient availability, it is influenced by the condition of solution pH, electrical conductivity, nutrient composition, and temperature. To make the right decision, farmers need real-time data about water conditions. In this research, NodeMCU ESP8266 is implemented as a microcontroller in the IoT-based hydroponic water condition monitoring system. The sensors used include HC-SR04 Ultrasonic Sensor, DS18B20 Temperature Sensor, and E-201C pH Sensor. Data read from all sensors can be viewed in real-time on a website that can be accessed via a smartphone [2].

The need for clean water for the people of Indonesia is very important, both are used for drinking water, cooking, bathing, and washing. However, the need for clean water is very difficult to fulfill in areas far from water sources, one of which is in the village of Pangkalan Lada, Central Kalimantan. Many residents still use rain-fed wells whose water quality is not always good. With this problem, the solution that can be applied in monitoring water quality by developing an IoT (internet of things) implementation of water quality monitoring and administration systems in small-scale clean water managers that display the state visually on monitoring features that can be controlled efficiently with wireless media through the website [3].

Based on the background described above, in its implementation, PT Smartneasy Nusantara still uses conventional methods in the process of watering the garden. This results in less than optimal utilization of water conservation in agriculture so to overcome existing problems by utilizing advances in technology, this research optimizes water conservation using IoT. This optimization process is expected to be able to streamline the use of water both in terms of amount and costs incurred, while also utilizing technological advances and making it easier to monitor the process of watering the garden every day.

The objective of the study is to create water conservation systems and sensors, which would facilitate the development of future systems. This would enable systems to optimize water conservation by using IoT sensors and to acquire systems integrated with IoT sensors in water usage. This would allow for the optimization of plant products while saving on manual and automatic processes, all aimed at achieving water conservation.

## 2. RESEARCH METHOD

### 2.1. Device Structure IoT

Below is the IoT platform structure to turn on the water pump based on temperature:

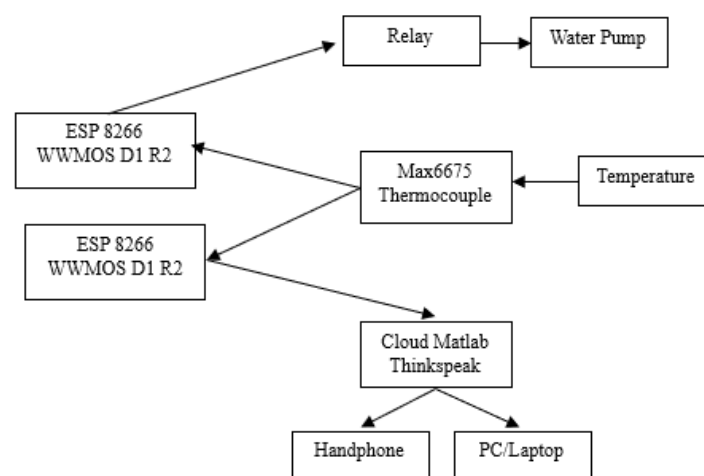

Figure 1. Device structure IoT.

Based on the framework developed at Max667, the thermocouple would obtain the temperature data from the plant's location. This data would then be sent to the microcontroller ESP8266 WeMOS D1 R2 and engineered to operate as a system for turning the relays of the water flusher engine on and off based on the prescribed temperature score. Technical abbreviations such as ESP8266 WeMOS D1 R2 should be explained when first used.

## 2.2. Flowchart Device

In general, the workings of the device can be explained in the following pictures:

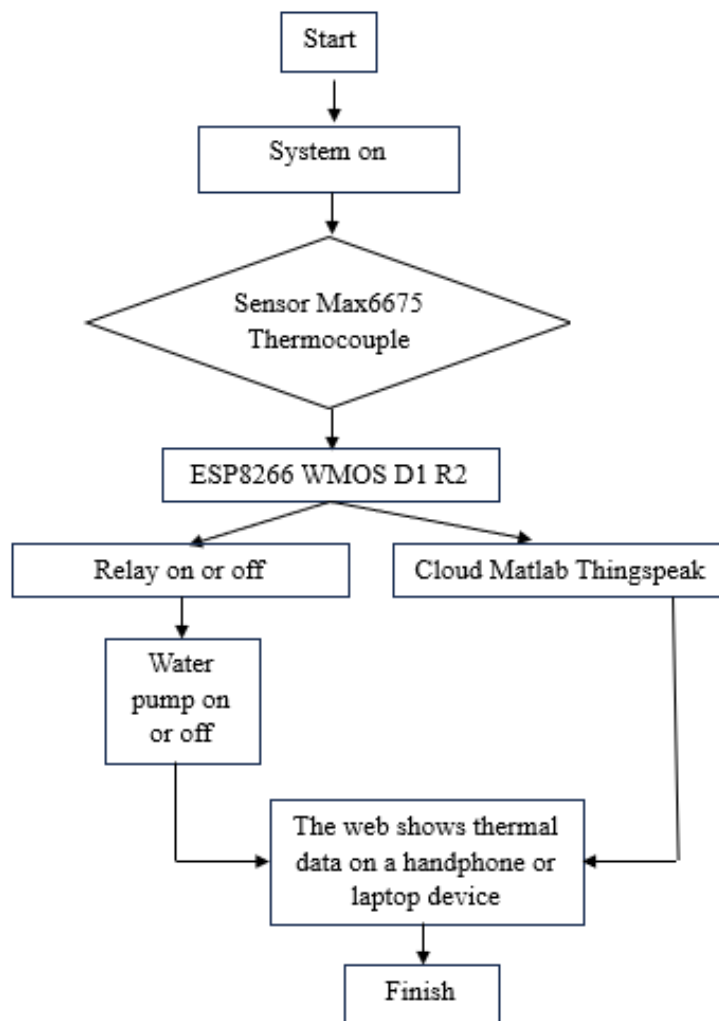

Figure 2. Flowchart device.

Based on Figure 2. in general, the working system of this tool is by means The temperature value will be captured by the Max6675 Thermocouple sensor, then the Max6675 Thermocouple will send the temperature data to the ESP8266 WeMOS d1 R2, ESP8266 will process the data with the C language from the Max6675 Thermocouple to the relay and the Thingspeak Matlab cloud, Relay will respond to data from ESP8266 to turn off or turn on the water pump according to the temperature that has been determined by the microcontroller, Cloud Matlab Thingspeak will receive data from ESP8266 via the internet and process it into

temperature monitoring data, Hardware Handphone or laptop can access and view temperature data generated from Max6675 Thermocouple.

### 2.3. Software and Hardware Design

Hardware comprises all the physical components of a device that use heat sensors to activate water, which will then execute a previous command from software. Software is a compilation of commands that a computer executes while performing its tasks. This software contains a storage apparatus for commands, as well as other documents and archives [4].

#### 2.3.1. Microcontroller ESP8266 WeMOS D1 R2

A microcontroller is a chip that functions as an electronic circuit controller and can generally store programs in it. Microcontrollers generally consist of a CPU, memory, certain I/O, and support units such as analog to digital converter (ADC) that are already integrated in it [5]. The microcontroller functions as both a relay interface and a data processor. Technical term abbreviations will be explained upon first usage. Micro controlling principles dictate the use of input/output facilities designed to receive input signals (input) and provide output signals (output). These signals are represented as 1 (high, equivalent to 5 volts) and 0 (low, equivalent to 0 volts) in a digital format [6].

#### 2.3.2. Max6675 Thermocouple

A thermocouple is a type of temperature sensor that is used to detect or measure temperature through two different types of metal conductors that are joined at the ends to create a “Thermoelectric” effect [7]. The Max6675 was created using an arduino driver that includes final cold compensation, linear corrections, and a 12-bit analog to digital converter with end-of-life thermocouple, providing serial resolution [8].

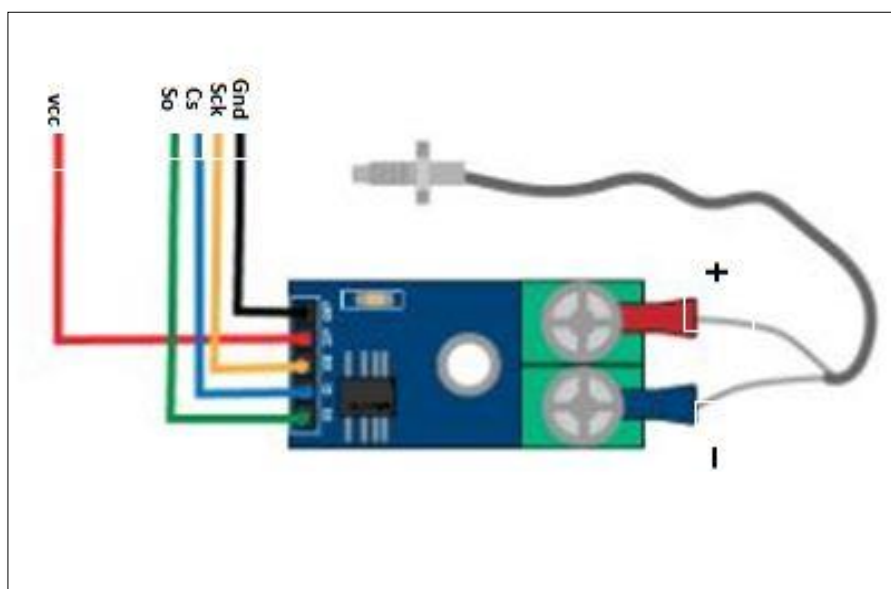

Figure 3. Skema sensor Max6675 Thermocouple.

Based on Figure 3. The main features of the Max6675 Thermocouple are as follows:

1. Simple SPI serial port output value.
2. 2°C to 1024°C temperature range, the temperature resolution of the converter is 0,25°C.

3. High impedance differential input.
4. Thermocouple disconnection detection.
5. Working voltage range 3~5 V, working current 50mA.
6. Operating temperature range -20°C ~ 85°C.
7. ESD signal 9, 2000 V.
8. Interface module: GND VCC SCK CS SO.
9. One power voltage: 3~5V DC.
10. Module size: 15 mm x 25 mm.

Below is the Max6675 pin chart used for ESP8266 and thermocouple as follows:

Table 1. Pin sensor Max6675 Thermocouple

Pin Max6675 for Esp8266	Pin Max6675 for Thermocouple
Pin SO	Pin + (Red wire)
Pin CS	Pin - (Blue wire)
Pin SCK	
Pin VCC	
Pin GND	

### 2.3.3. USB 3.0

The USB is an electronic device that converts 150 mA to 5 V. Its function includes operating as a power supply, as well as a battery or battery discharge [9]. The USB was selected due to its ability to generate a constant voltage for the board node-MCU to receive. Below are the USB 3.0 specifications used:

1. Input: 150 mA.
2. Output: 4.0 output to 5,25 V.
3. DC jack: 5,5/2,1 mm.
4. Dimensions: 8,5 x 6,5 x 4,6 cm (P x L x T).

### 2.3.4. Design Software and Hardware

The designer of this software utilized ideas from arduino software, which affords the benefit of an inherent library while simultaneously adding support for other microcontrollers. The device comprises crucial hardware components including the ESP8266 WeMOS D1 R2 microcontroller, MAX6675 thermocouple, water pump, relay, cloud Matlab, and web Thingspeak [10].

The programming of microcontrollers involves the utilization of C language in three fundamental parts. The initial section pertains to variable storage, which serves as data storage locations for essential information such as wifi names, passwords, and fire tokens [1]. The second segment entails the void setup function, executed as the first function after the microcontroller is powered on in order to provide command initialization. The final component of the third part is the void loop, which executes after the completion of the void setup. Voloop functions are integral to the primary program and run sequentially from the start to the end, repeatedly.

## 2.4. Assembly of Hardware

This process of assembling the device with the raw materials described requires several stages, the stages as follows:

1. Assembly control module relay.

2. Assembly module cloud matlab thingspeak.
3. A series of top component details:
  - a. Relay pin.
  - b. Max6675 Thermocouple pin sequence.

### 2.5. Mockup of a View on Web Thingspeak

Thingspeak is a system that can schedule and run Matlab code using the version of Matlab that Math Works hosts in the cloud [11]. This web-based Thingspeak display presents information on water usage, including minute-by-minute temperature graphs displaying temperature in degrees Celsius that are color-coded. Additionally, the status of the lights indicates the relay for life and death [12].

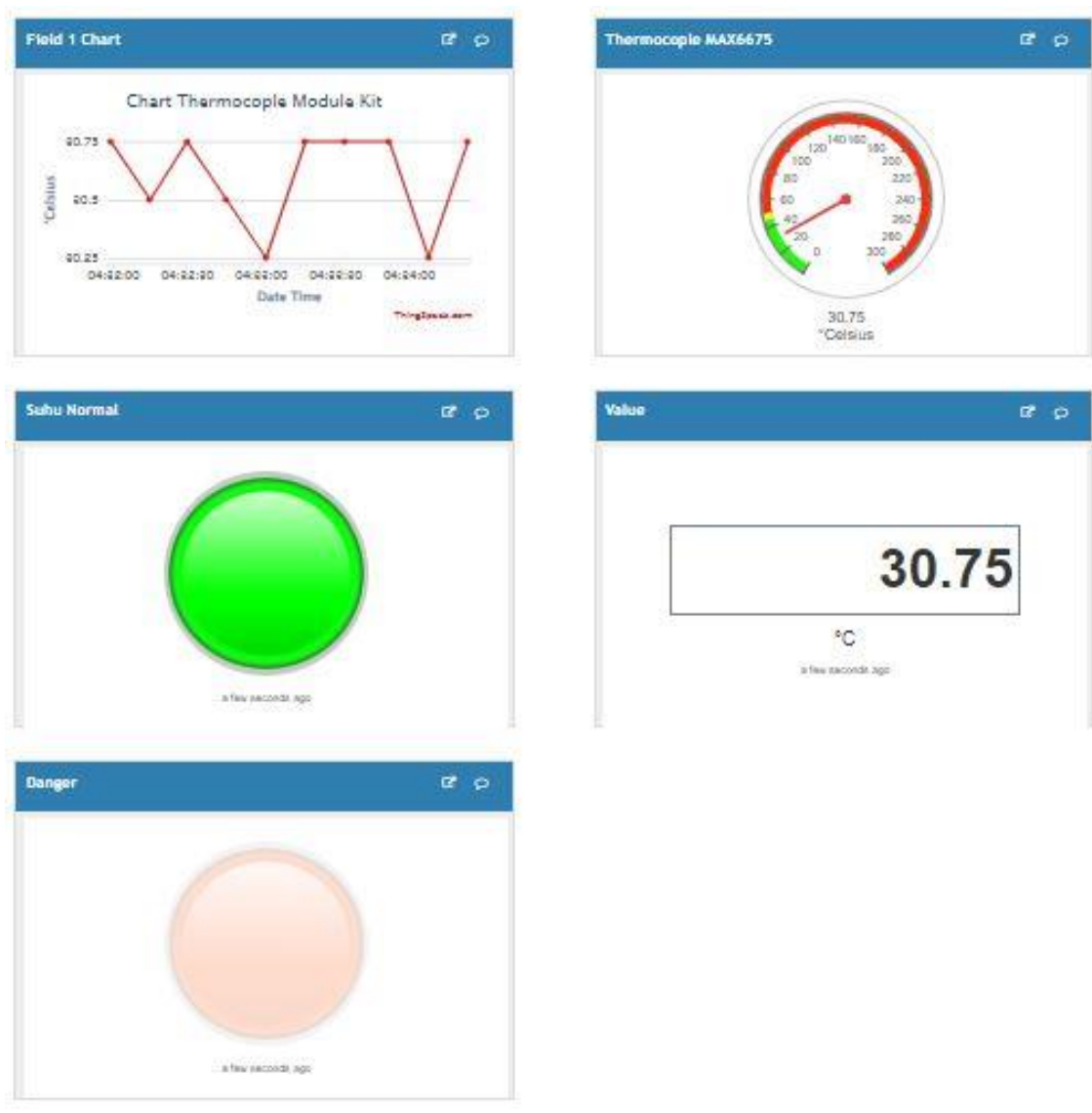

Figure 4. Mockup of a view on web thingspeak

Based on Figure 4 above, it can be explained that the information displayed in this web thingspeak consists of a field chart that is used to view statistical changes based on existing data whether the temperature is too hot or already according to the standard, there is a display of

temperature values and there is also a thermocouple indicator display that shows whether the temperature has exceeded the predetermined standard temperature limit or not. Then the green indicator means that the temperature is within the standard and the red indicator means that the temperature is above the specified standard.

## 2.6. Functional Testing

Testing functional units to determine whether the required components can function correctly in response to the given commands [13].

### 2.6.1. Testing Microcontrol ESP8266 WeMOS D1 R2

ESP8266 WeMOS D1 R2 is equipped with a push button, namely the reset and flush buttons. Although the ESP8266 WeMOS D1 R2 uses the Lua language, this language has the same logic and programming structure as the C language, only the syntax is different [14]. ESP8266 WeMOS D1 R2 is also supported with Arduino IDE software by setting the board manager on the Arduino IDE [15]. Before using this board, you must flash it first so that it supports the tool that will be used. When using Arduino IDE, you must use suitable firmware, namely the Ai-Thinker firmware that supports AT Command. The use of the Firmware loader tool that must be used is the ESP8266 WeMOS D1 R2 Firmware [16].

Testing all pins of the ESP8266 WeMOS D1 R2 allows for a comprehensive evaluation of their functionality. The following steps outline the process for testing the ESP8266 WeMOS D1 R2. By conducting this test, the functionality of each pin and port can be established. This enables a full understanding of the characteristics of this particular microcontroller [2]. Testing all pins of the ESP8266 WeMOS D1 R2 allows for a comprehensive evaluation of their functionality:

1. Multimeter release.
2. High or low port I/O voltage measurements used.

### 2.6.2. Max6675 Thermocouple Sensor Testing the Relay

The aim of the Max6675 Thermocouple sensor testing and associated experimentation was to ascertain the efficacy and functionality of the devices employed, as well as to gain a comprehensive understanding of the workings of these two components, encompassing both circuit and programming aspects [17].

### 2.6.3. System Test Work

The objective of testing the operational system is to determine whether the testing software can execute correctly with the established hardware circuit and the pre-existing web controls. This ensures that the system functions adequately and without errors.

## 3. RESULTS AND DISCUSSION

---

Testing on soil conditions made a research site within 7 days resulted in the temperature conditions for the soil as follows:

Table 2. Soil Testing Temperature Conditions

Day	Morning Soil (Celcius)	Early afternoon soil (Celcius)	Afternoon soil (Celcius)
Day-1	28°	32°	28°
Day-2	26°	30°	27°
Day-3	27°	31°	28°
Day-4	28°	32°	27°

Day-5	28°	32°	27°
Day-6	29°	32°	28°
Day-7	28°	31°	28°

According to the table provided, an average temperature of 29°C was recorded under conditions where the soil was mixed with water and under conditions where the soil was not mixed with water. The resultant average temperature of 7 days was 34°C and is used as a reference point to trigger sprinklers through temperature sensors. Accordingly, if soil temperature readings are below 34°C, the soil is moist, otherwise, it is dry.

After calculating the average temperature over a period of 7 days to serve as a temperature reference, the subsequent monitoring process utilizes web thingspeak. If the indicator on the green monitor detects that the ground temperature falls below 34°C, the relay disengages the current, preventing the sprinklers from being activated.

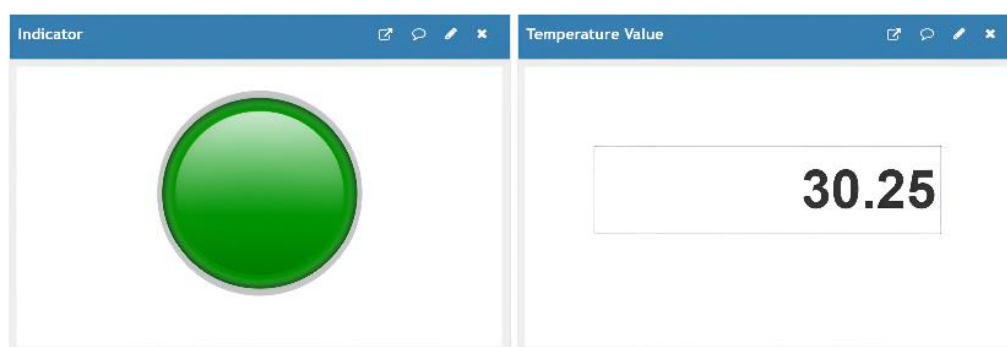

Figure 5. Green indicator

If the monitoring device displays red indicators, it indicates that the soil conditions exceed 34°C. Subsequently, the relays will activate and establish the required electrical connections for the sprinkling process.

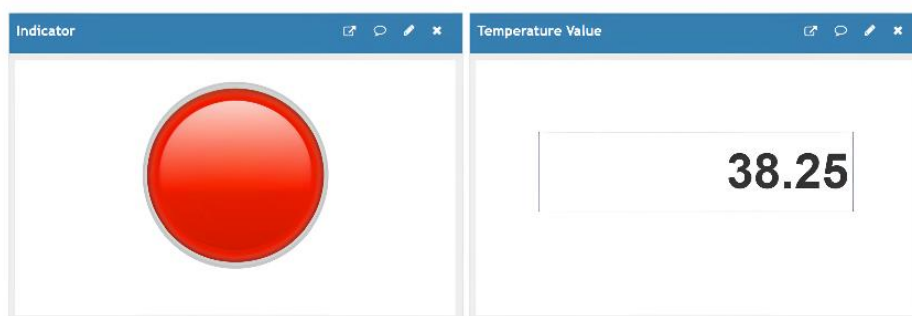

Figure 6. Red indicator

During flushing, it takes around 30 minutes to restore soil temperature by 34°C or below 34°C in soil conditions above 34°C. Technical abbreviations will be explained upon their first use. If the soil temperature reaches 34°C or below, the web-based monitoring display on Thingspeak turns green after the sprinkler pump's power is cut off. The text has a logical flow of information, a clear structure, and uses value-neutral language.



#### 4. CONCLUSION

---

Based on the research conducted, it can be concluded that IoT modules can be designed from the early stages to optimize water conservation. The testing and implementation of the device have shown that it works as intended. Through temperature monitoring and sensor data processing, devices can optimize water usage consistently. Technical abbreviations such as IoT should be defined at first use.

#### REFERENCES

- [1] P. Studi, "Rancang Bangun Smart Meter System untuk Penggunaan Air pada Rumah Tangga Berbasis Internet Of Things (Smart Meter System Design for Water Usage in Households Based on Internet of Things)." [Online]. Available: <http://jcosine.if.unram.ac.id/>.
- [2] R. A. Murdiyantoro, A. Izzinnahadi, and E. U. Armin, "Sistem Pemantauan Kondisi Air Hidroponik Berbasis Internet of Things Menggunakan NodeMCU ESP8266," *Journal of Telecommunication, Electronics, and Control Engineering (JTECE)*, vol. 3, no. 2, pp. 54–61, Sep. 2021, doi: 10.20895/jtece.v3i2.258.
- [3] F. Febrianti, S. Adi Wibowo, and N. Vendyansyah, "Implementasi IoT (Internet of Things)", *JATI*, Vol. 5, No. 1.
- [4] D. Puiianto, M. Asia, J. A. Jend Yani No, A. Tanjung Baru, and S. Selatan Korespondensi, "Implementasi Internet Of Things (IOT) Pada Smart Cooker," *Jik*, vol. 13, no. 1, pp. 43–51, 2022.
- [5] M. Babiuch, P. Foltynnek, and P. Smutny, "Using the ESP32 microcontroller for data processing," *Proceedings of the 2019 20th International Carpathian Control Conference, ICCO 2019*, no. May 2019, 2019, doi: 10.1109/CarpathianCC.2019.8765944.
- [6] T. Kusuma and M. T. Mulia, "Perancangan Sistem Monitoring Infus Berbasis Mikrokontroler Wemos D1 R2," *Konferensi Nasional Sistem Informasi*, pp. 1422–1425, 2018.
- [7] A. M. Maghfiroh, S. Y. Setiawan, B. Trisono, A. Pambudi, and S. Nyatte, "Measurement of Temperature Distribution Stability Using a Data Logger with 9 Channels Based on the Type K Thermocouple Sensor," vol. 15, no. 3, pp. 167–173, 2022.
- [8] R. Ananda Pratama and M. Arman, "Sistem Akuisisi Data Temperatur Showcase Berbasis IoT Menggunakan ESP32 dengan Sensor Termokopel dan Logging ke Google Spreadsheets."
- [9] Yin Sun, Student Member, Hank Lin, Bin-Chyi Tseng, and David Pommerenke, "Mechanism and Validation of USB 3.0 Connector Caused Radio Frequency Interference," *IEEE*, vol. 62, pp. 1169–1178, 2019, doi: <https://doi.org/10.1109/TEM.2019.2925935>.
- [10] Burlian and C. Bella, "Rancang Bangun Penjadwalan Otomatis Pemberian Air Pada Akuaponik Berbasis Arduino Uno R3," *Portaldata*, vol. 2, no. 2, pp. 1–12, 2022.
- [11] C. Prastyadi, B. Utomo, H. G. Ariswati, D. Titisari, S. Sumber, and A. S. Kumar, "Eight Channel Temperature Monitoring using Thermocouple Sensors (type K) Based on Internet of Thing using ThinkSpeak Platform," *Journal of Electronics, Electromedical Engineering, and Medical Informatics*, vol. 5, no. 1, pp. 33–38, 2023, doi: 10.35882/jeeemi.v5i1.276.
- [12] H. Miry and G. A. Aramice, "Water monitoring and analytic based ThingSpeak," *International Journal of Electrical and Computer Engineering*, vol. 10, no. 4, pp. 3588–3595, 2020, doi: 10.11591/ijece.v10i4.pp3588-3595.
- [13] F. Ulya, M. Kamal, and Azhar, "Rancang Bangun Sistem Monitoring Cuaca Dengan Tampilan Thingspeak," *Jurnal Tektro*, vol. 1, no. September, p. 1, 2017.
- [14] P. R. Adinda and T. Komputer, "PENYIRAMAN TANAMAN OTOMATIS BERBASIS IoT MENGGUNAKAN NodeMCU ESP8266," *Portaldata.org*, vol. 2, no. 9, pp. 2022–2023, 2023.

- [15] Mariza Wijayanti, "Prototype Smart Home Dengan Nodemcu Esp8266 Berbasis Iot," *Jurnal Ilmiah Teknik*, vol. 1, no. 2, pp. 101–107, 2022, doi: 10.56127/juit.v1i2.169.
- [16] A. D. Pangestu, F. Ardianto, and B. Alfaresi, "SISTEM MONITORING BEBAN LISTRIK BERBASIS ARDUINO NODEMCU ESP8266," vol. 4, no. 1, 2019.
- [17] M. N. Bashir and K. M. Yusof, "A review of relay network on uavs for enhanced connectivity," *J Teknol*, vol. 82, no. 1, pp. 173–183, 2020, doi: 10.11113/jt.v82.13183.